

Dell™ LTO Media Handbook

Version 2.0

Last Modified 05/05/05

Information in this document is subject to change without notice.
© 2005 Dell Inc. All rights reserved.

Reproduction in any manner whatsoever without the written permission of Dell Inc. is strictly forbidden.

Trademarks used in this text: *Dell*, the *DELL* logo, *PowerEdge*, and *PowerVault* are trademarks of Dell Inc.; *Microsoft* and *Windows* are registered trademarks of Microsoft Corporation.

Other trademarks and trade names may be used in this document to refer to either the entities claiming the marks and names or their products. Dell Inc. disclaims any proprietary interest in trademarks and trade names other than its own.

May 2005

12/15/2006

Table of Contents

1	List of Tables.....	4
2	List of Figures	5
3	Revisions and Ownership Information	Error! Bookmark not defined.
4	Introduction	6
5	Dell PowerVault 110T LTO Drives and Media	7
5.1	Drive Types and Basic Characteristics – Dell LTO-1 Drives	7
5.2	Drive Types and Basic Characteristics – Dell LTO-2 Drives	8
5.3	Drive Types and Basic Characteristics – Dell LTO-3 Drives	9
5.4	Media types used in Dell PowerVault 110T LTO drives	10
5.5	Media Color Schemes.....	10
6	Invalid Media Symptoms	12
7	Cartridge Memory (CM)	13
8	Migrating LTO media	14
9	WORM Media	15
10	Cleaning.....	16
10.1	Label designations on LTO cleaning media.....	16
10.2	Cleaning media usage and drive cleaning lights.....	16
10.3	Expired Cleaning Tape Characteristics	17
11	Stuck Tapes.....	18
12	Diagnostics	19
12.1	Troubleshooting Cleaning/Read/Write errors	19
12.2	Dell PowerEdge Diagnostics	19
12.3	Drives with internal self test features	20
13	Erasing a prewritten LTO Tape	22
14	Media Handling	23
14.1	Media description	23
14.2	Perform a Thorough Inspection.....	23
14.3	Handle the Cartridge Carefully.....	24
14.4	Ensure Proper Packaging if shipping tapes	25
14.5	Cartridge Storage Conditions	26
14.6	Cartridge life.....	26
14.7	Media Do's and Do Not's.....	27

1 List of Tables

Table 1 - LTO Drive Types and Basic Characteristics	7
Table 2 - LTO-2 Drive Types and Basic Characteristics	8
Table 3 - LTO-3 Drive Types and Basic Characteristics	9
Table 4 - Media Type per Drive.....	10
Table 5 - Cleaning Characteristics Per Drive.....	16
Table 6 - Characteristics of expired LTO cleaning tape in various drives.....	17
Table 7 - Tape Environmental Specifications.....	26

2 List of Figures

Figure 1- Dell PowerVault 110T LTO.....	7
Figure 2- Dell PowerVault 110T LTO-1	7
Figure 3- Dell PowerVault 110T LTO-1	7
Figure 4 - Dell PowerVault 110T LTO-2	8
Figure 5 - Dell PowerVault 110T LTO-2-L (Certance).....	8
Figure 6 - Dell PowerVault 110T LTO 3.....	9
Figure 7 - Ultrium-1 Media.....	10
Figure 8 - Ultrium-2 Media.....	10
Figure 9 - Ultrium-3 Media.....	10
Figure 10 - WORM media - two toned	10
Figure 11 - Universal Cleaning Tapes	16
Figure 12 - DellOnline PowerEdge Diagnostics – Tape	19
Figure 13- Setting the Write-Protect Switch.....	22
Figure 14 LTO Ultrium Data Cartridge	23
Figure 15- Correct leader pin location	23
Figure 16- Media Inspection 1- bad tape	24
Figure 17- Split seem on LTO tape.....	25
Figure 18- Media Inspection 2- good tape.....	25

3 Introduction

This document describes media compatibility, handling, and usage for all Dell™ PowerVault™ 110T LTO Drives.

4 Dell PowerVault 110T LTO Drives and Media

4.1 Drive Types and Basic Characteristics – Dell LTO-1 Drives



			
	<i>Figure 1- Dell PowerVault 110T LTO</i>	<i>Figure 2- Dell PowerVault 110T LTO-1</i>	<i>Figure 3- Dell PowerVault 110T LTO-1</i>
Capacity (native/compressed)	100 GB/200 GB	100 GB/200 GB	100 GB/200 GB
Native Speed	15 MB/s	15 MB/s	15 MB/s
Primary Media	Ultrium-1	Ultrium-1	Ultrium-1
Physical Device Description	<ul style="list-style-type: none"> • Single air intake along bottom. • Eject button in top right corner • Status lights (Vertical) <ul style="list-style-type: none"> - Power - Activity - Error - Status 	<ul style="list-style-type: none"> • Ultrium-1 label on drive bezel. • Split air intakes on both corners at the bottom • Flush mount eject button • Status lights (Vertical) <ul style="list-style-type: none"> - Ready - Drive error - Tape error - Use cleaning cartridge 	<ul style="list-style-type: none"> • Blue eject button • 7 segment display • Only sold on 132T drive sled
Used in:	<ul style="list-style-type: none"> • Dell PV110T LTO table top and internal standalone • Dell PV 122T • Dell PV 136T • Dell PV 114T 	<ul style="list-style-type: none"> • Dell PV110T LTO-1 table top and internal standalone 	<ul style="list-style-type: none"> • Dell PV 132T

Table 1 LTO Drive Types and Basic Characteristics

4.2 Drive Types and Basic Characteristics – Dell LTO-2 Drives



Figure 4 - Dell PowerVault 110T LTO-2



Figure 5 - Dell PowerVault 110T LTO-2-L (Certance)



		
	<i>Figure 4 - Dell PowerVault 110T LTO-2</i>	<i>Figure 5 - Dell PowerVault 110T LTO-2-L (Certance)</i>
Capacity (native/compressed)	200 GB/400 GB	200 GB/400 GB
Native Speed	35 MB/s	26 MB/s
Primary Media	Ultrium-2	Ultrium-2
Physical Device Description	<ul style="list-style-type: none"> • Blue eject button • 7 segment display • Ultrium-2 label 	<ul style="list-style-type: none"> • Ultrium-2 label • LEDs (Vertical) <ul style="list-style-type: none"> - Power - Activity - Error - Status
Used in:	<ul style="list-style-type: none"> • Dell PV 132T • Dell PV136T • Dell PV 122T • Dell PV110T LTO-2 table top and internal standalone • Dell PV 114T 	<ul style="list-style-type: none"> • Dell PV110T LTO-2-L table top and internal standalone • NOT used in PE 800 or PE1800

Table 2 - LTO-2 Drive Types and Basic Characteristics

4.3 Drive Types and Basic Characteristics – Dell LTO-3 Drives

	 <p data-bbox="740 638 1130 663"><i>Figure 6 - Dell PowerVault 110T LTO 3</i></p>
Capacity (native/compressed)	400 GB/800 GB
Native Speed	80 MB/s
Primary Media	Ultrium-3
Physical Device Description	<ul style="list-style-type: none"> • Blue eject button • 7 segment display • Ultrium-3 label
Used in:	<ul style="list-style-type: none"> • Dell PV132T • Dell PV 136T • Dell PV110T LTO-3 table top and internal standalone • Dell PV 114T

Table 3 - LTO-3 Drive Types and Basic Characteristics

4.4 Media types used in Dell PowerVault 110T LTO drives



				
	<i>Figure 7 - Ultrium-1 Media</i>	<i>Figure 8 - Ultrium-2 Media</i>	<i>Figure 9 - Ultrium-3 Media</i>	<i>Figure 10 - WORM media - two toned</i>
Part No.	340-7240	340-8701		
Dell PowerVault 110T LTO	Primary	No support	No support	No support
Dell PowerVault 110T LTO-1	Primary	No support	No support	No support
Dell PowerVault 110T LTO-2	Backward Compatible – Read/Write	Primary	No support	No support
Dell PowerVault 110T LTO-2-L (Certance)	Backward Compatible – Read/Write	Primary	No support	No support
Dell PowerVault 110T LTO 3	Backward Compatible – Read-Only	Backward Compatible – Read/Write	Primary	Optional

Table 4 - Media Type per Drive

4.5 Media Color Schemes

- Dell LTO-1 media is black and marked with the Ultrium-1 label. (See figure 7)
- Dell LTO-2 media is purple and marked with the Ultrium-2 label. (See figure 8)
- Dell LTO-3 media is blue-gray and marked with the Ultrium-3 label. (See figure 9)
- Dell LTO-3 WORM (write once read many) media is gray on the bottom and the same blue-gray color on the top and is marked with a WORM label. (See figure 10)

Note: WORM media that is not labeled “Dell” is always two toned with gray on the bottom and uses the respective color chosen by the tape vendor on the top. The WORM label will be present on the media regardless of media vendor.

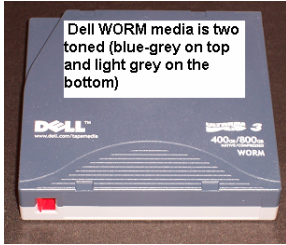
- All Dell LTO cleaning media is black. Depending on the vintage of the cartridge it may be marked Ultrium 1, 2, 3 or a combination of the 3. (See figure 11)

Note: There can be no guarantee that all Ultrium- *x* tapes will be the same color. Please pay attention to the Ultrium label on the tape to determine correct media for your drive. Although Dell brands their own media, all certified media vendors are supported for use in Dell products. Dell recommends the use of Dell branded media in all Dell PowerVault LTO drives.

5 Invalid Media Symptoms

Symptoms of using invalid media:

1. Cleaning light comes on
2. Media light may flash or stay on
3. Tape ejects
4. Nothing – backup software says invalid media
5. Drives with a seven segment display displays a **7** on the LEDs

6 Cartridge Memory (CM)

Tape drives require information about the tape cartridge being used. For LTO tape cartridges, this information is stored in a small chip within the tape itself referred to as Cartridge Memory (CM). This chip contains nonvolatile memory which responds through a passive radio frequency interface.

In addition to the type of cartridge, the CM holds a selection of important information which the drive uses to setup and calibrate. The CM also contains a tape directory to be able to quickly search for data sets. If for some reason the cartridge memory is damaged or corrupted, the user will experience difficulty with the cartridge.

If the cartridge memory fails, the user data can be recovered. To recover the data, set the write protect tab on the cartridge and load the cartridge into an Ultrium drive. The drive stores enough information on tape to be able to recognize the tape. The data directory however is lost. For this reason the drive can only search from the beginning of tape (BOT) to end of tape (EOT) across all wraps to find the data. The drive cannot search fast (Fast Search option) to the correct location to find the needed data set. Recovery of a full tape of data could take up to 3 hours.

7 Migrating LTO media

Known issues for media migration from one manufacturer to another have been fixed through drive firmware. Regardless of what vendor or OEM product is being used to create media, always use the latest available firmware for the drive. This will ensure optimal performance for migrating tape between different drive vendors.

Note: Linear Tape-Open (LTO) technology is built on an open standard. Migrating media from one drive manufacturer to another is fully supported.

Note: As of LTO-3 all LTO media is at least backward read compatible. (see *table 4* for details)

8 WORM Media

LTO-3 WORM media stands for Write Once, Read Many. This means once data is written to a piece of WORM media, the data on the tape cannot be changed or overwritten. The media also stores unique identifiers which allow the drive to determine whether or not the media has been tampered with.

WORM media offers a method of data retention for compliance laws such as the Sarbanes-Oxley Act of 2002. Specific WORM media barcode labels will end in **LT**. Currently, only LTO-3 drives have the ability to read from and write to WORM media. WORM media is not compatible with LTO-1 or LTO-2 drives.

9 Cleaning

Note: LTO drives in general do not require frequent cleaning.

9.1 Label designations on LTO cleaning media.

For the last several years, cleaning tapes for LTO drives have been **UCC** (universal cleaning cartridges). Prior to the **universal** or **for use with all** designation of cleaning media, vendor specific cleaning media was used. For the purposes of this document only **universal** or **for use with all** cleaning media will be discussed. If a tape is not labeled **universal** or **for use with all**, then Dell recommends the user to purchase a tape with that designation.

Note: As of this document, LTO-1, 2, and 3 all use the same cleaning media although it might not be labeled as such depending on the vintage of the tape.

9.2 Cleaning media usage and drive cleaning lights

Note: New UCC tapes are labeled as "**For Use With All Ultrium 1, 2, & 3 Drives**"



Figure 11 - Universal Cleaning Tapes

Physical Description	Black tape labeled with "used for all Ultrium drives"		
Part Number	310-5084		
Drive Type	# of Tape Motion Hours before Cleaning Light Illuminates	# of uses before expires cleaning tape	how is the cleaning required displayed
Dell PowerVault 110T LTO	not supported	15	Use cleaning Cartridge light
Dell PowerVault 110T LTO-1	500	50	Status light
Dell PowerVault 110T LTO-2- L (Certance)	500	50	Power light on Solid-Green, Status light on Solid-Amber
Dell PowerVault 110T LTO-2	not supported	50	C on 7 segment display
Dell PowerVault 110T LTO-3	40 full tape passes = 16TB or 8TB with verify enabled *	50	C on 7 segment display

Table 5 -Cleaning Characteristics Per Drive

* The Dell PowerVault LTO-3 tape drive has enabled period (maintenance) cleaning on the drive by default. Do not be alarmed if you are seeing cleaning light come on more frequently than you are used to seeing on Dell PowerVault LTO-2. If you perform a backup with **verify**, you will see a cleaning request twice as frequently as when **verify** is not used. This is because **verify** enabled will double the amount of passes the tape makes over the head. Most backup applications support Tape Alert. If the drive is requesting cleaning the backup software should notify the user of the need to clean.

9.3 Expired Cleaning Tape Characteristics

Drive Type	Cleaning with a Good Tape	Cleaning with an Expired Tape
Dell PowerVault 110T LTO	Ready light blinks green - Use cleaning cartridge light comes on solid - ejects tape.	Ready light blinks green - ejects tape out shortly after loading.
Dell PowerVault 110T LTO-1	(Power light on Solid-Green, Activity light on Solid-Green, Status light on Solid-Amber) Eject tape when done.	Power light on Solid-Green, Activity light on Solid-Green, Status light Blinks-Amber and the tape is ejected shortly after inserting.
Dell PowerVault 110T LTO-2	No 7 segment display indicator. Activity light blinks green and tape ejects when finished.	Pre firmware 53Y3 - No 7 segment display indicator. Activity light blinks green but ejects tape much quicker - shortly after loading. Firmware 53Y3 and newer. - No 7 segment display shows 7, Activity light blinks amber, and tape is ejected shortly after inserting. When tape is completely removed all light indicators go out.
Dell PowerVault 110T LTO-2-L (Certance)	Power light on Solid-Green, Activity light on Solid-Green, Status light on Solid-Amber. Ejects tape when done.	Power light on Solid-Green, Activity light on Solid-Green, Status light Blinks-Amber and the tape is ejected shortly after inserting.
Dell PowerVault 110T LTO-3	No 7 segment display indicator. Activity light blinks green and tape ejects when finished.	No 7 segment display shows 7, Activity light blinks amber, and tape is ejected shortly after inserting. When tape is completely removed all light indicators go out.

Table 6 Characteristics of expired LTO cleaning tape in various drives

The cleaning light on an LTO drive can come on for two reasons.

1. A periodic maintenance threshold has been exceeded.
2. A high error rate has occurred

This can happen for 3 reasons.

- A head clog
- A hardware failure on the drive
- Bad or marginal media. (see Troubleshooting Cleaning/Read/Write errors)

Note-1: Run Dell Online PowerEdge™ Diagnostics to determine media or hardware related failures.

Note-2: Dell Online Power Edge Diagnostics does not support Dell PowerVault 110T LTO (see figure 1)

10 Stuck Tapes

There is a good possibility that a stuck tape was generated by dropped or damaged media. Different drives will react differently if damaged media is inserted. Some may eject a tape and some tapes may become permanently stuck in the drive and require a drive return. Most LTO drives have a capability to reset the drive in the event of a stuck tape or other non-responsive drive issues. Attempting this drive reset may or may not help in removing a stuck tape.

Note: Dell PowerEdge Diagnostics also includes a **Media Eject** test that can be run to force an eject on a tape.

	How to perform a device reset on Dell PowerVault 110T LTO drives
Dell PowerVault 110T LTO	Insert a paper clip into the reset hole on the front panel of the drive
Dell PowerVault 110T LTO-1	Press and hold the Eject button for more than 5 seconds and release the Eject button – press Eject again to eject tape
Dell PowerVault 110T LTO-2-L (Certance)	Press and hold the Eject button for more than 5 seconds. The tape should eject within 40 seconds.
Dell PowerVault 110T LTO-2	Press and hold the Eject button for more than 10 seconds and release the Eject button – press Eject again to eject tape.
Dell PowerVault 110T LTO-3	Press and hold the Eject button for more than 10 seconds and release the Eject button - press Eject again to eject tape

11 Diagnostics

11.1 Troubleshooting Cleaning/Read/Write errors

If Clean, Read, or Write errors are reported by backup software try alternate pieces of media before replacing tape drives.

To troubleshoot errors with tape drives, you need to determine the root of the problem. Tape related problems can come from two primary sources; Media and Hardware. Dell Online PowerEdge Diagnostics can be used under either Microsoft® Windows® or Linux to narrow down the likely cause. This tool can be downloaded for free from support.dell.com.

Within the Diagnostic tools there is a **Media test** which can be run in a long test or quick test mode to help with the diagnosis. The quick test will fill 20 percent of the tape and the long test will write to 80 percent. Reading, writing, spacing, and verifying will all happen during this test so do not use it as a performance tool.

Note: The **Media test** will overwrite data on the tape. Dell suggests using a blank (new) or scratch piece of media.

In the event of a failure complete the following procedure.

1. Run the test on one tape. (We suggest running the full test if you think the errors occur later in the backup – run the short test if errors tend to occur early in the backup)
2. If a failure occurs, mark the tape and set it aside.
3. Insert another tape and rerun the same test.
4. If failure occurs, clean the drive and try a 3rd tape.
5. If failures persist, contact Dell Support.

11.2 Dell PowerEdge Diagnostics

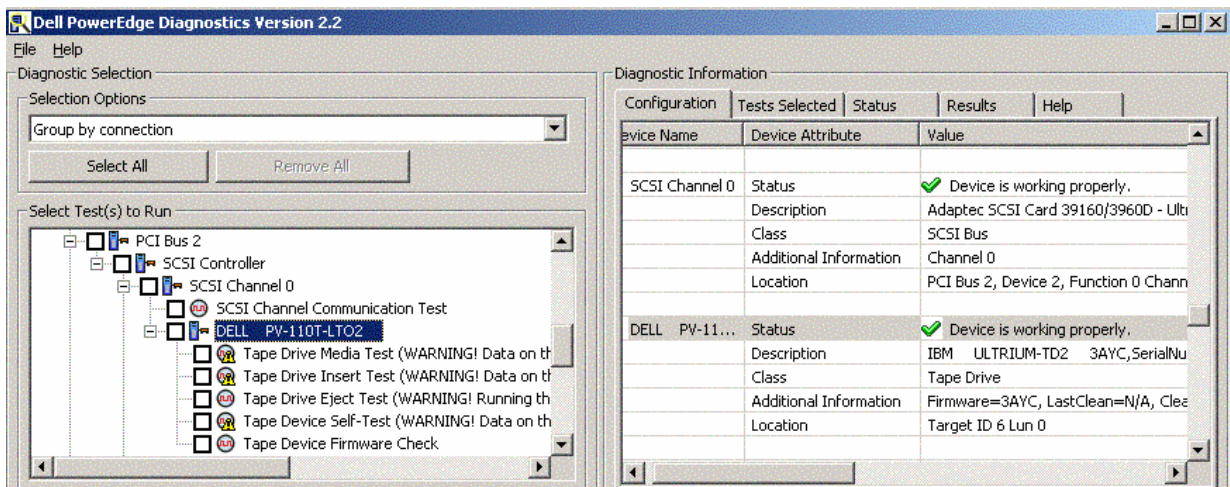

Figure 12 - DellOnline PowerEdge Diagnostics – Tape

Dell Online PowerEdge Diagnostics can be used to troubleshoot tape drives in Linux and Windows.

Note: At the time this document is being written, a tape device driver must be loaded in Windows device manager in order to run Dell PowerEdge Diags Version 2.2. Future version may eliminate this requirement.

Tests included in Dell PowerEdge Diagnostics are the following:

1. The media can be used to determine if errors are related to tape hardware or certain pieces of media.
 - The media test can be run in full mode which will fill 80 percent of the tape.
 - The media test can also be run in quick mode that will fill 20 percent of the tape.

Note: These tests could take between 2 to 5 hours. Read, Write, space, rewind, and verify will be run to exercise the drive and media.

2. The **Drive Insert test** will test the capabilities of the drive to mount, thread, and do a short write operation to the tape. A tape must be present in the drive to run this test.
3. The **Tape Drive Eject test** can be used to try to eject a stuck tape. This test will not work under true hardware failures. If the stuck tape is due to software this test could work when trying to eject a stuck tape.
4. The **Tape Device Self test** can be used to do a quick verify of drive operations without spending hours writing to tape in search of bad media as seen in the Media test. This test will usually finish within 5 minutes.
6. Use the **Tape Device Firmware Check** test to verify that the drive firmware is up-to-date. New firmware can fix many types of known issues.

Note: If a tape is stuck in an LTO drive the firmware can not be updated.

11.3 Drives with internal self test features

Dell PowerVault 110T LTO-2 drives running the latest version of firmware and Dell PowerVault 110T LTO-3 drives have the ability to do internal device self tests that do not require any other software or host attachment.



Fast Read/Write test – ‘F’ – Quickly verify the functionality of the drive.

To verify the functionality of the drive using a **Fast Read/Write** test:

- 1: Press the **Eject** button quickly 3 times within 2 seconds.
- 2: **0** will illuminate.
3. Toggle through the seven segment LED by pressing the eject button until you reach **F**.
4. Press and hold the **Eject** button for 5 seconds then release.
5. **C** will be displayed – insert a scratch cassette

The **F** on the drive will blink while the drive goes through 10 cycles of reading writing and eject/inserts. Each cycle takes 3 minutes. To halt the test, press the **Eject** button. This test will measure the throughput of the drive and check for media errors. If there is an error it will be displayed on the 7 segment LED. If an error occurs, clean the drive and rerun the test with a different piece of media to make sure it is not a media related issue. If the issue persists contact Dell Technical Support.

Run Tape Drive diagnostics – ‘1’ - More comprehensive longer write test – This test is better for isolating errors between drive and media than the ‘F’ test.

To run the Tape Drive test:

- 1: Press the **Eject** button quickly 3 times within 2 seconds.
- 2: **0** will illuminate.
3. Toggle through the seven segment LED by pressing the **Eject** button. Stop when you get to **1**.
4. Press and hold the **Eject** button for 5 seconds then release.
5. **C** will be displayed – insert a scratch cassette

The **F** on the drive will blink while the drive goes through 10 cycles of reading writing and eject/inserts. Each cycle takes 20 minutes. To halt the test press the eject button. This test will measure the throughput of the drive and check for media errors. If there is an error it will be displayed on the seven segment LED. If an error occurs, clean the drive and rerun the test with a different piece of media to make sure it is not a media related issue. If the issue persists contact Dell Technical Support.

12 Erasing a prewritten LTO Tape

Notice: Write-protection will not prevent a cartridge from being erased by bulk-erasure or degaussing. Do not bulk erase Ultrium format cartridges. This will destroy pre-recorded servo information and render the cartridge unusable.

The erase feature in backup software is the preferred method for erasing an LTO tape. To prevent erasing a tape set the write protect switch.

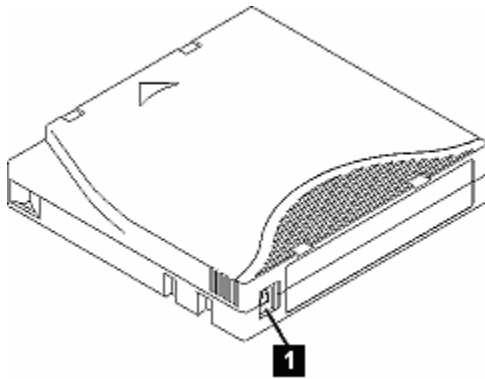

Figure 13- Setting the Write-Protect Switch

13 Media Handling

13.1 Media description

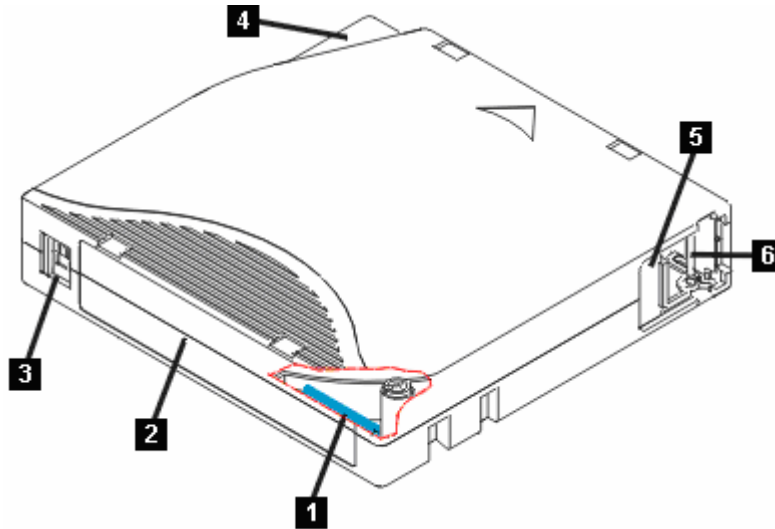

Figure 14 LTO Ultrium Data Cartridge

1. LTO cartridge memory
2. Label area
3. Write-protect switch
4. Insertion guide
5. Cartridge door
6. Leader pin

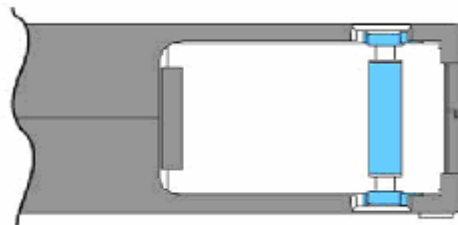

Figure 15- Correct leader pin location

13.2 Perform a Thorough Inspection

- Inspect the cartridge's packaging to determine potential rough handling.
- When inspecting a cartridge, open only the cartridge door. Do not open any other part of the cartridge case. The upper and lower parts of the case are held together with screws; separating them destroys the usefulness of the cartridge. While the door is open check that the leader pin is properly seated. Best practice is to open the door and check the pin is properly seated before each use. See figure 15.
- Inspect the cartridge for damage before using or storing it.

- Inspect the rear of the cartridge (the part that you load first into the tape load compartment) and ensure that there are no gaps in the seam of the cartridge case. If there are gaps in the seam, the leader pin may be dislodged. See Figure 16.
- If you suspect that the cartridge has been mishandled but it appears useable, copy any data onto a good cartridge immediately for possible data recovery. Discard the mishandled cartridge.

13.3 Handle the Cartridge Carefully

- Do not drop the cartridge. If the cartridge drops, slide the cartridge door back and ensure that the leader pin is properly seated in the pin-retaining spring clips.
- Do not handle tape that is outside the cartridge. Handling the tape can damage the tape's surface or edges, which may interfere with read or write reliability. Pulling on tape that is outside the cartridge can damage the tape and the brake mechanism in the cartridge.
- Do not stack more than six cartridges.
- Do not degauss a cartridge that you intend to reuse. Degaussing makes the tape unusable.

Below is an image of dropped tape which resulted in an out of place leader pin. This cartridge if inserted into a drive could result in a stuck tape. Other damage could result in the leader pin missing all together, i.e. dropped inside the tape housing.



Figure 16 Media Inspection 1- bad tape

Below is an image of a tape that had been dropped and the **cartridge seam** has been split.

Note: Newer versions of LTO tapes have plastic welded seams that can prevent splitting from occurring; however, tapes still need to be checked for leader pins that have dropped inside the cassette housing if they have been dropped.



Figure 17- Split seam on LTO tape

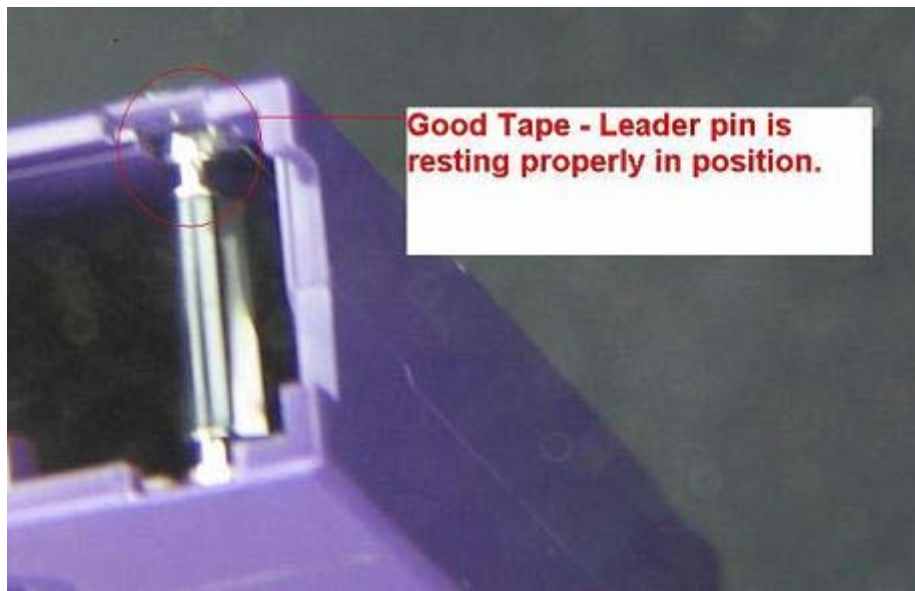

Figure 18 Media Inspection 2- good tape

13.4 Ensure Proper Packaging if shipping tapes

- When you ship a cartridge, ship it in its original or better packaging.
- Always ship or store a cartridge in a jewel case.
- Use only a recommended shipping container that securely holds the cartridge in its jewel case during transportation.
- Never ship a cartridge in a commercial shipping envelope. Always place it in a box or package.
- If you ship the cartridge in a cardboard box or a box of a sturdy material, ensure the following:

- Place the cartridge in polyethylene plastic wrap or bags to protect it from dust, moisture, and other contaminants.
- Pack the cartridge snugly. Do not allow it to move around.
- Double-box the cartridge (place it inside a box, then place that box inside the shipping box) and add padding between the two boxes

13.5 Cartridge Storage Conditions

Provide Proper Acclimation and Environmental Conditions

- Before you use a cartridge, let it acclimate to the normal operating environment for 24 hours.
- Ensure that all surfaces of a cartridge are dry before inserting it.
- Do not expose the cartridge to moisture or direct sunlight.
- Do not expose recorded or blank cartridges to stray magnetic fields (for example, terminals, motors, video equipment, X-ray equipment, or fields that exist near high-current cables or power supplies). Such exposure can cause the loss of recorded data or make the blank cartridge unusable.
- Maintain the following environmental conditions outlined in the table below.

Environmental Specifications				
Environmental Factor	Operating	Operational Storage	Archival Storage	Shipping
Temperature	10 to 45 degrees C (50 to 113 degrees F)	16 to 32 degrees C (61 to 90 degrees F)	16 to 25 degrees C (61 to 77 degrees F)	-23 to 49 degrees C (-9 to 120 degrees F)
Relative humidity (non-condensing)	10 to 80%	20 to 80%	20 to 50%	5 to 80%
Wet bulb temperature	26 degrees C (79 degrees F)	26 degrees C (79 degrees F)	26 degrees C (79 degrees F)	26 degrees C (79 degrees F)

Table 7 Tape Environmental Specifications

13.6 Cartridge life

- ▶ Durability - 1,000,000 passes on any area of tape, equates to over 20,000 end-to-end passes/260 full tape backups
- ▶ Archival life – 30 years.

13.7 Media Do's and Do Not's

Do

- ▶ Store cartridges in their protective cases
- ▶ Handle cartridges with great care
- ▶ Store cartridges vertically
- ▶ Align cartridges so the grooves interlock
- ▶ Inspect cartridges prior to each use
- ▶ Unload cartridges prior to powering down the drive
- ▶ Allow a 24-hour conditioning period to the operating temperature and humidity before using new or stored cartridges.
- ▶ Eject media before powering off the drive

Do Not

- ▶ Touch the media or leader with bare fingers
- ▶ Use pens or pencils during cartridge inspection
- ▶ Drop cartridge
- ▶ Stack cartridges horizontally
- ▶ Disassemble cartridges
- ▶ Ship cartridges in drive
- ▶ Store near magnetic fields (e.g. speakers, monitors, electric motors, power supplies, etc.)
- ▶ Use a cartridge that fell from 3 ft or higher
- ▶ Degauss LTO tapes
- ▶ Ship the LTO drive with media loaded